

# Nox Switch 30W

technical lighting

4241-N, 4242-N

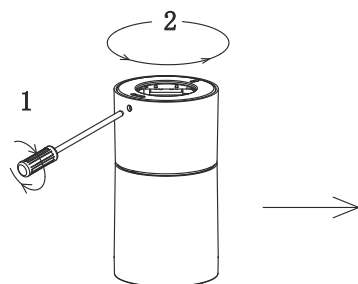

1. Loosen the M3 screws by screw driver  
2. Rotate the back base off the lamp anti-clock wire

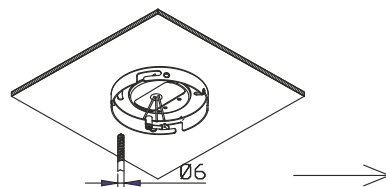

3. Drill 2 holes 6mm diameter on the ceiling according to position on back base

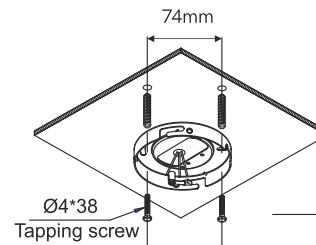

4. Fix the back base on the ceiling by tapping screws

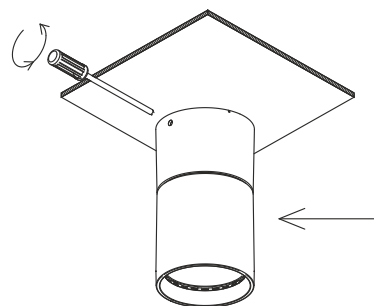

7. Lock it by screw, finish installation.

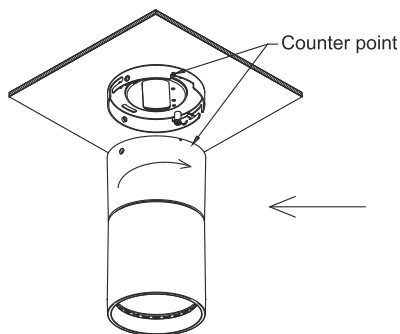

6. Align the driver box to the counterpoint, and rotate clock wire to fix onto the back base

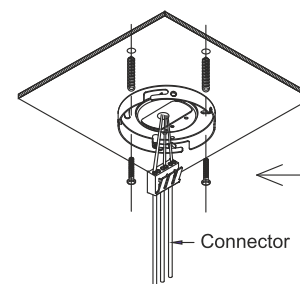

5. Connect the AC power to the connectors

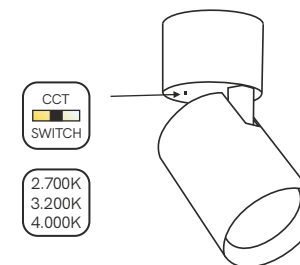

3 YEARS WARRANTY	30.000 HOURS	20 IP	UGR <19	>0,9 PF	≥94 CRI
220/240 VAC	50/60 Hz	+50°C -20°C	15° 24° 40°	CCT SWITCH 2.700K 3.200K 4.000K	2.460 Lm