

DOTFIX

Ref.:105025

Empotrable de la familia DOTFIX con acabado mate y de diseño compacto. Tiene un haz de luz focalizado que permite iluminar cualquier punto sin deslumbrar.



EAN: 8426107020116

Más información:

sulion.es/ean/8426107020116.es

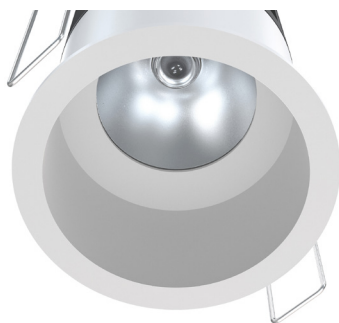
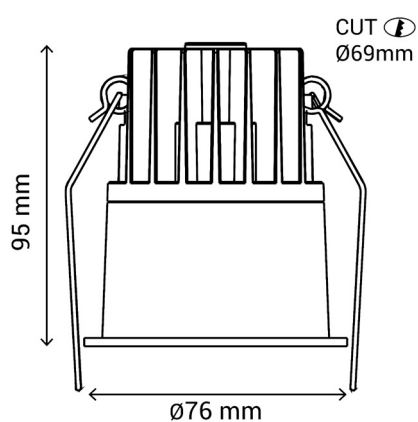

Color	Blanco RAL 9003
Acabado	Mate
Material	Aluminio // Policarbonato
Fuente de Luz	LED COB
Potencia luminaria	15 W
Temperatura de color	2700-4000-6000 K
Flujo lumínico	900 lm
Ángulo de apertura	15°
CRI	CRI 90
Horas de vida	50000 h
Número de encendidos	30000
Regulable	No
IP	20
Clase	II
Voltaje	AC 220-240 V
Frecuencia	50-60 Hz
Temperatura de trabajo	-10 <-> +40°C
Peso bruto	<0.5 Kg

