

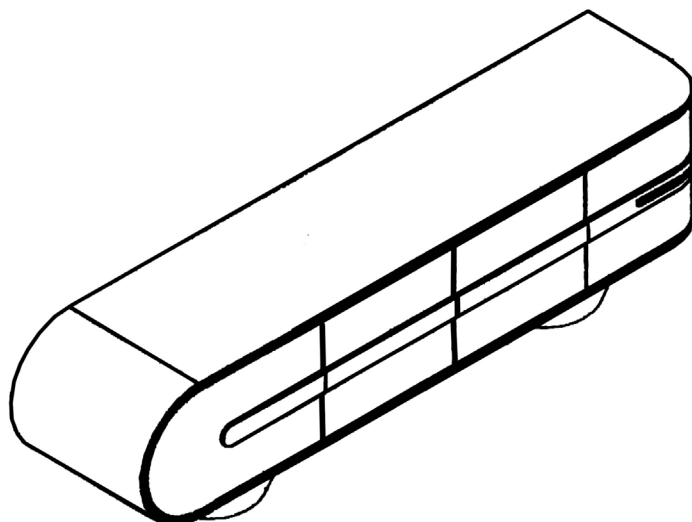



El montaje y la manipulación de este artículo debe hacerse entre dos personas.



A: 	B: 	C: 	E: 
8PCS	8PCS	8PCS	1PCS



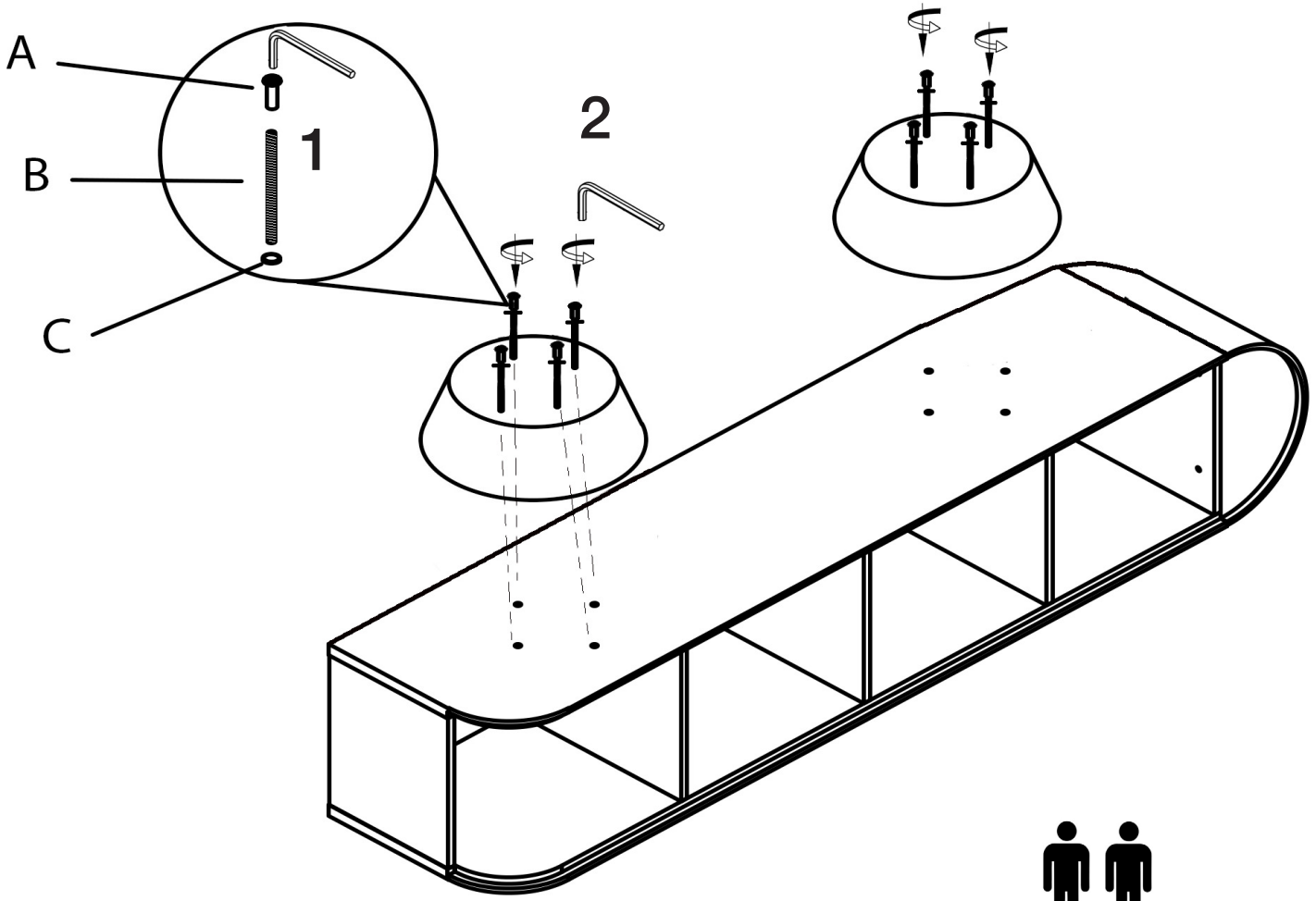

Para ver la ficha técnica de producto completa, puede usar el siguiente código QR:



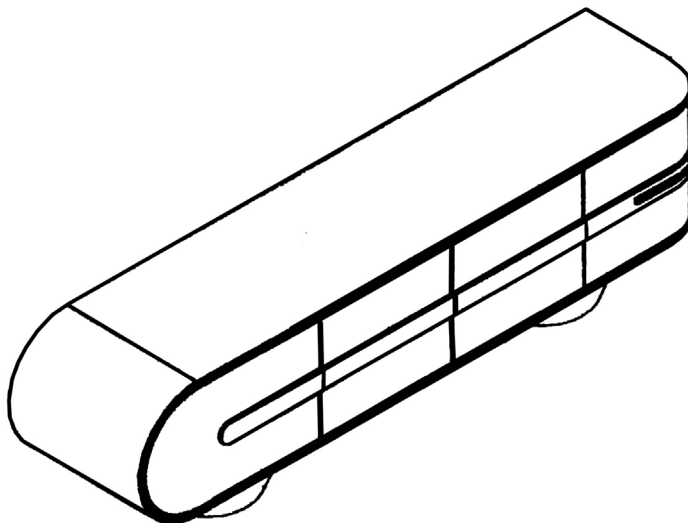

IMPORTANT NOTE
 The assembly of this lamp
 must be done by **two people**



A: 	B: 	C: 	D: 	E: 
8PCS	8PCS	8PCS	20 PCS	1PCS

You may use the following QR code to view the complete technical data sheet of the product:



If you have any technical questions, please do not hesitate to contact our technical Department.
 We are at your disposal in our email: export@schuller.es